

Installation of optional Mounting Kit for 73 Series Heat Exchanger; P/N: 00925-03

The Exergy heat exchanger mounting kit includes all of the hardware required to properly mount one heat exchanger. The heat exchanger may be mounted on a panel with through holes or with tapped holes. All hardware is stainless steel. Each kit contains all items listed below.

P/N: 00925-01

- 2 upper clamps (counterbored holes)
- 2 lower clamps (straight holes)
- Hardware for mounting to tapped holes
 - 4 5/16-24 x 2.75" long socket head cap screws (torque to 95 lb-in (10.7 N-m))
 - 4 5/16 high collar lock washers
- Hardware for mounting to through holes
 - 4 5/16-24 x 3.00" long socket head cap screws (torque to 95 lb-in (10.7 N-m))
 - 4 5/16 flat washers
 - 4 5/16-24 self locking thin nuts

P/N: 00925-02

- 2 mounting stand-off (2 counterbored holes & 2 tapped holes)
- Hardware for mounting to tapped holes
 - 4 5/16-24 x 1.00" long socket head cap screws (torque to 95 lb-in (10.7 N-m))
 - 4 5/16 high collar lock washers
- Hardware for mounting to through holes
 - 4 5/16-24 x 1.25" long socket head cap screws (torque to 95 lb-in (10.7 N-m))

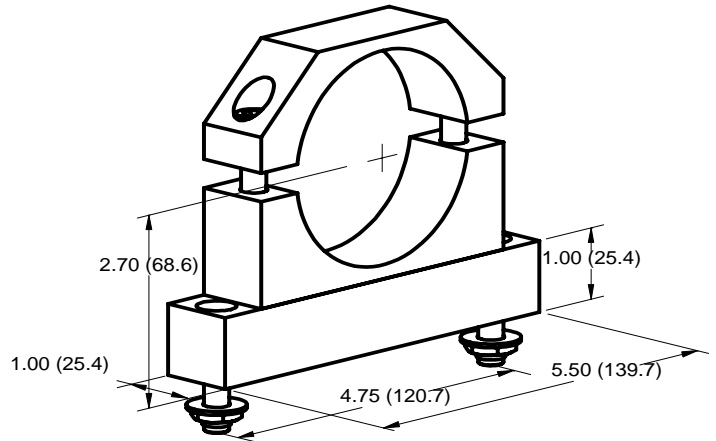
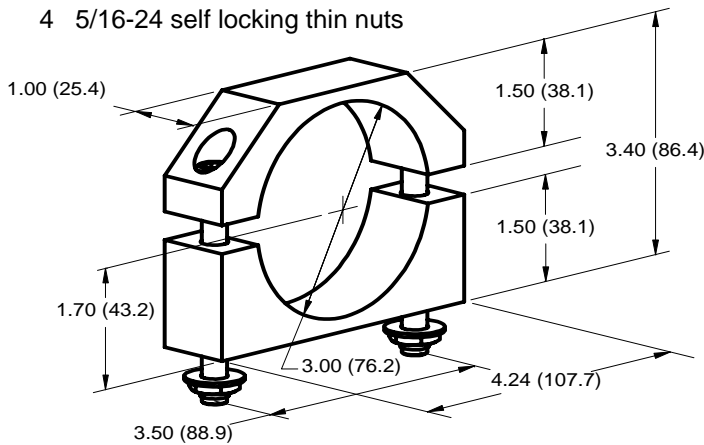

DIMENSIONS ARE IN INCHES (mm)

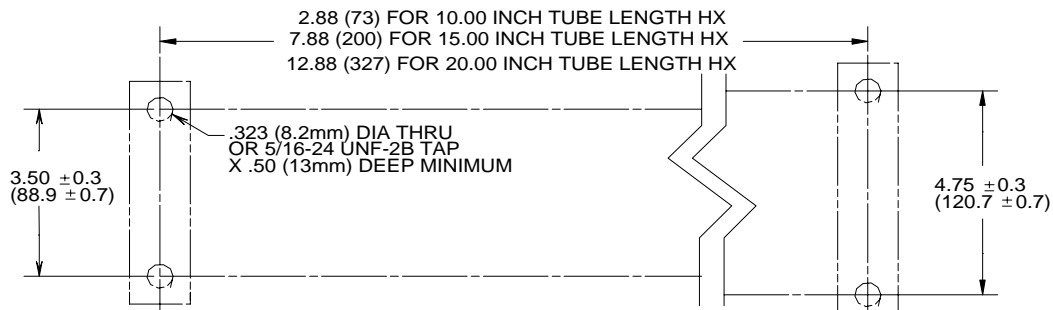

MAXIMUM PANEL THICKNESS FOR THROUGH HOLE MOUNTING IS .38 IN. (9.5mm) USING SCREWS PROVIDED

MOUNTING HOLE PATTERNS

